

输出功率: 约0.5~8.0W

碳刷马达

典型应用: 电子门锁
后视镜
家用电器

OUTPUT: APPROX 0.5~8.0W

Carbon-brush Motors

Typical Applications: Electronic Door Lock
Rearview Mirror
Household Appliances

1. OUTLINE DRAWING:

UNIT:MM

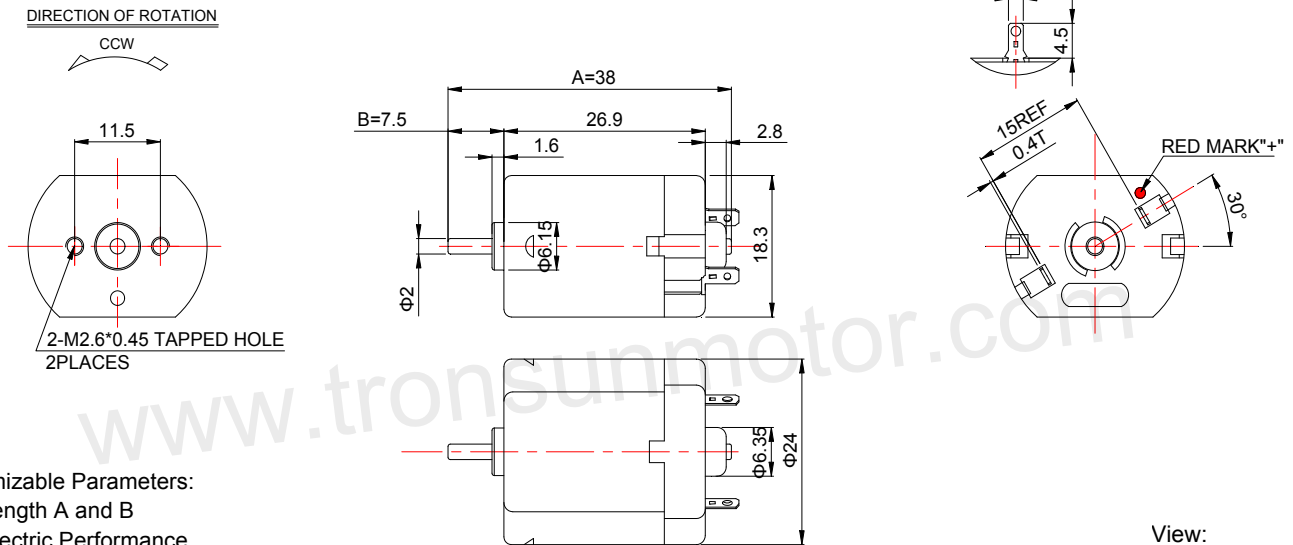

Customizable Parameters:

1. Length A and B
2. Electric Performance
3. Direction of Rotation
4. Eccentric Wheel is available

WEIGHT: 29g(Approx)

View:

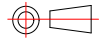

2. MOTOR PERFORMANCE :

MODEL	VOLTAGE		NO LOAD		AT MAXIMUM EFFICIENCY					STALL		
	OPERATING RANGE	NOMINAL V	SPEED rpm	CURRENT A	SPEED rpm	CURRENT A	TORQUE g.cm	TORQUE mN.m	OUTPUT W	TORQUE g.cm	TORQUE mN.m	CURRENT A
FK-260SA-2197	3.0~7.0	6.0	13000	0.185	10760	0.87	34.5	3.39	3.80	200	19.63	4.20
FK-260SA-12300	6.0~13.0	12.0	8700	0.045	7177	0.21	20.5	2.01	1.50	117	11.48	1.00

